

LED Street Light Housing MLT-SLH-FM-II



Brief Introduction

This LED street light housing fixture MLT-SLH-FM-II is the medium size of SMD LED street light housing fixture from Moonlight LED street light F series. Modern design, precision die-casting molded and superior corrosion resistant coating finish housing with standard twist lock photocell mounting platform, make this housing can be used for variety of LED roadway lighting applications.

MOONLIGHT TECHNOLOGY LIMITED

Feature

- ✧ Durable aluminum alloy die-casting LED street light housing for heavy-duty outdoor lighting applications.
- ✧ Ribbon-free and compact design.
- ✧ Easy drainage system.
- ✧ Separate LED light engine and driver box for easy maintenance.
- ✧ Tool-less design for replace the LED driver without any tool.
- ✧ Large driver box complies with variety of drivers and dimming options.
- ✧ Both cover and bottom of the driver box have the GND bosses for security.
- ✧ Plastic electrostatic spraying to resist corrosion, chipping and fading.
- ✧ Adjustable knuckle slip fitter help to adjust the led street light fixture on-site for optimal photometric performance, which make sure that the light distributions, are specifically adapted to the real needs of the area to be lit.
- ✧ Side-entry or post-top mounting. Universal mounting pieces allows precise adjustment on-site.
- ✧ 5mm high light transmittance tempered glass diffuser.
- ✧ Silicon gaskets.
- ✧ SUS304 stainless steel bolts for fastening.
- ✧ The powder coated die-cast clips make it a harmonious overall with the rest of the luminaire.
- ✧ Twist lock photocell mounting platform for lighting control.
- ✧ Quick disconnection terminal block mounting platform for disconnect the power supply for linemen handling security.
- ✧ IP66 rated, protect from all dust and harsh weather.
- ✧ Standard sanded gray finish.
- ✧ Easy to assemble, install and linemen friendly maintain.

MOONLIGHT TECHNOLOGY LIMITED

Mechanical Dimensions

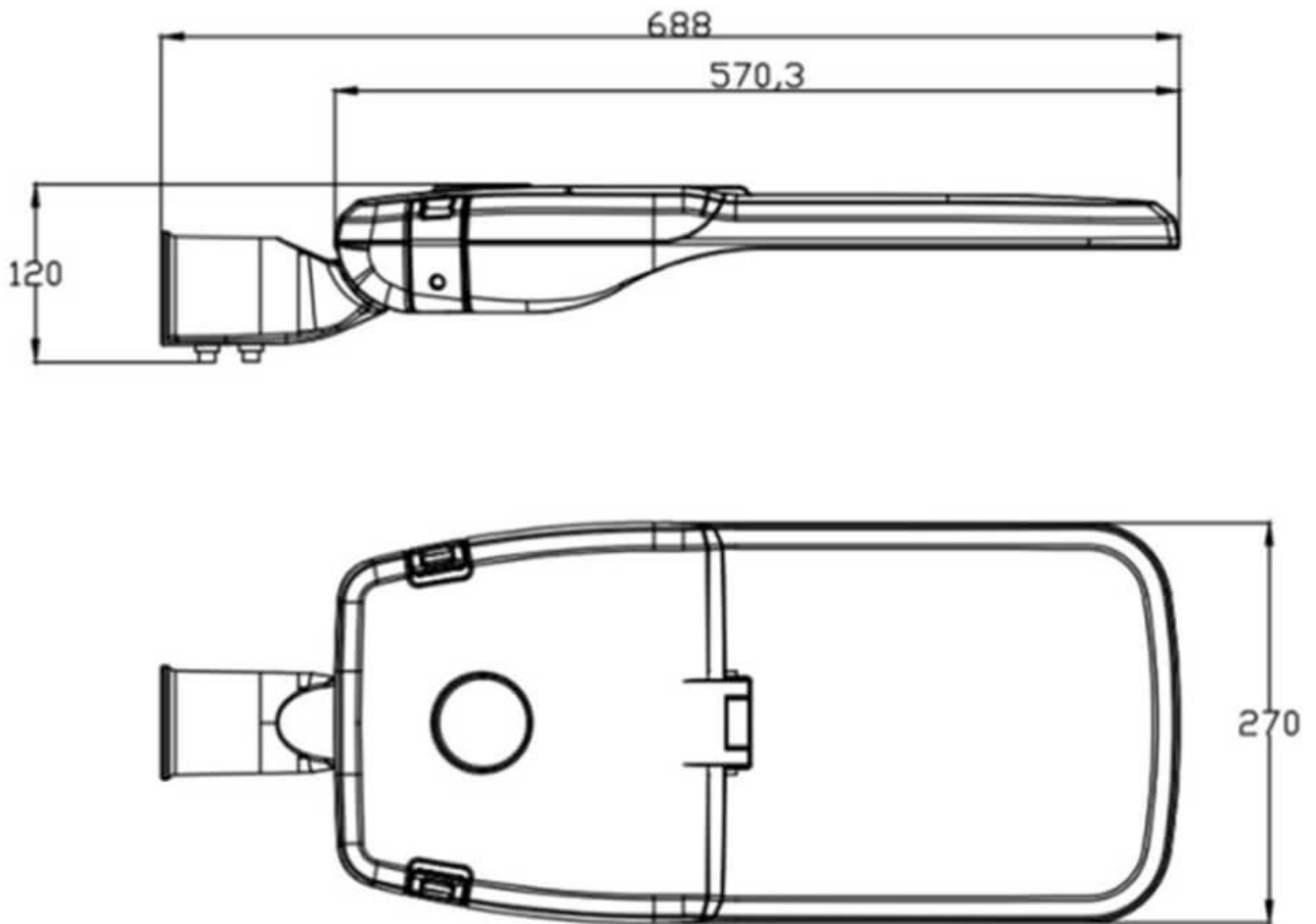

MOONLIGHT TECHNOLOGY LIMITED

Parameter

Model No.	LED Street Light Housing MLT-SLH-FM-II
Dimension of Housing	66.8cm(L)*27.0cm(W)*12.0cm(H)
Fixture Material	Die-casting Aluminum Alloy
Surface Finish Color	Sanded Gray or Customized color
Material of Diffuser	High Transmittance Tempered glass
Effective MCPCB Mounting Size	214mm(L)*160mm(W)
Recommended LED Power	80W to 120W
Driver Box Dimension	180mm(L)*90mm(W)*70mm(H)
Pole Mounting	Accommodates up to Φ 65mm pipe
Adjustable Slip Fitter	-15° to +15°
Standard Photocell	Optional
Quick Disconnection Terminal Block	Optional
IP Rating	IP66

Pictures

Front View



Back View



MOONLIGHT TECHNOLOGY LIMITED

Packing Information

Net Weight	5.00kg/PCS
Gross weight	6.0kg/carton
Quantity	1PCS/ carton
Carton Size	74cm(L)*33cm(W)*15.5cm(H)

Application

This heavy-duty, modern design and cost-effective LED street light housing fixture is typically used as 80W-120W LED street lighting fixture. LED street lighting is used extensively in urban settings, along small town downtown main streets, in residential neighborhoods, in commercial districts, public squares, in industrial parks, at interstate highway interchanges, bridges, and rural intersections.

MOONLIGHT TECHNOLOGY LIMITED



Developed modular optical lens design for a precise light distribution according To the specific needs of the site to be lit , easily removed and replaced on-site To take advantage of future technological developments , specifically dedicated to Offering photometric flexibility and performance.

