

LED Street Light Housing MLT-SLH-DXS-II



Brief Introduction

This LED street light housing fixture MLT-SLH-DXS-II is the smallest size of SMD LED street light housing fixture from Moonlight LED street light D series. Modern design, precision die-casting molded and superior corrosion resistant coating finish housing with standard twist lock photocell mounting platform, make this LED street light housing can be used for variety of LED roadway lighting applications.

MOONLIGHT TECHNOLOGY LIMITED

Feature

- ✧ Durable aluminum alloy die-casting LED street light housing for heavy-duty outdoor lighting applications.
- ✧ Casting-integral heat sink with fins increased air flow velocity providing maximum passive thermal management.
- ✧ Easy drainage fins system.
- ✧ Separate LED light engine and driver box for easy maintenance.
- ✧ Tool-less design for replace the LED driver without any tool.
- ✧ Large driver box complies with Meanwell HVG series drivers.
- ✧ Both cover and bottom of the driver box have the GND bosses for security.
- ✧ Plastic electrostatic spraying to resist corrosion, chipping and fading.
- ✧ Adjustable knuckle slip fitter with SUS304 stainless steel hardware secures fixture to pole arm.
- ✧ Side-entry or post-top mounting. Universal mounting pieces allows precise adjustment on-site.
- ✧ 5mm high light transmittance tempered glass diffuser.
- ✧ Silicon gaskets.
- ✧ SUS304 stainless steel bolts and clips for fastening
- ✧ Standard S6000 socket and twist lock photocell mounting platform for lighting control.
- ✧ Quick disconnection terminal block mounting platform for disconnect the power supply for linemen handling security.
- ✧ IP66 rated, protect from all dust and harsh weather.
- ✧ Standard Gray finish.
- ✧ Easy to assemble, install and linemen friendly maintain.

MOONLIGHT TECHNOLOGY LIMITED

Mechanical Dimensions

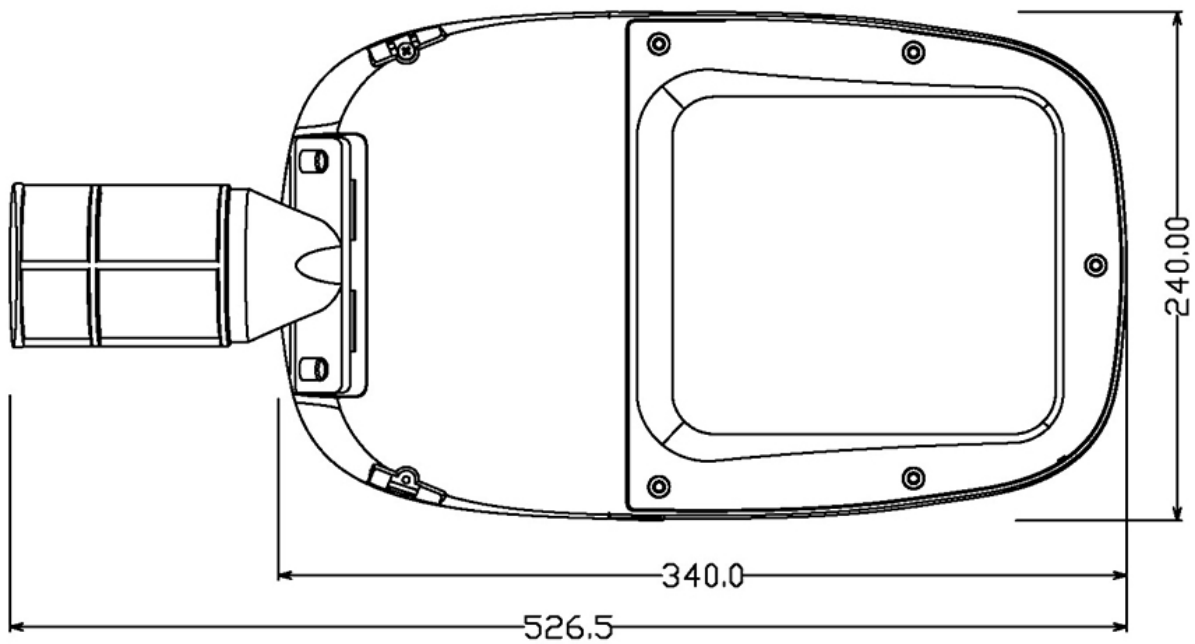
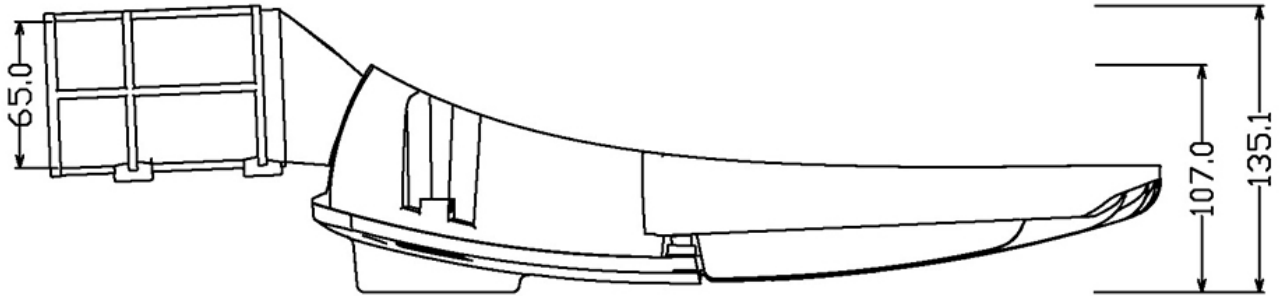

MOONLIGHT TECHNOLOGY LIMITED

Parameter

Model No.	LED Street Light Housing MLT-SLH-DXS-II
Dimension of Housing	52.7cm(L)*24cm(W)*13.5cm(H)
Fixture Material	Die-casting Aluminum Alloy
Surface Finish Color	Gray or Customized color
Material of Diffuser	High Transmittance Tempered glass
Effective MCPCB Mounting Size	191mm(L)*169mm(W)
Recommended LED Power	30W to 60W
Driver Box Dimension	199mm(L)*81mm(W)*55mm(H)
Pole Mounting	Accommodates up to Φ 65mm pipe
Adjustable Slip Fitter	-15° to +15°
Standard Photocell	Optional
Quick Disconnection Terminal Block	Optional
IP Rating	IP66

Pictures

Front View

Back View

MOONLIGHT TECHNOLOGY LIMITED



Packing Information

Net Weight	2.9kg/PCS
Gross weight	3.5kg/carton
Quantity	1PCS/ carton
Carton Size	57cm(L)*29cm(W)*17cm(H)

Application

This heavy-duty, modern design and cost-effective LED street light housing fixture is typically used as 30W-60W LED street lighting fixture. LED street lighting is used extensively in urban settings, along small town downtown main streets, in residential neighborhoods, in commercial districts, public squares, in industrial parks, at interstate highway interchanges, bridges, and rural intersections.