

LED Street Light Housing MLT-SLH-BL-II



Brief Introduction

This LED street light housing fixture MLT-SLH-BL-II is the large size of SMD LED street light housing fixture from Moonlight LED street light B series. Modern design, precision die-casting molded and superior corrosion resistant coating finish housing with standard twist lock photocell mounting platform, make this housing can be used for variety of LED roadway lighting applications.

Feature

- ✧ Durable aluminum alloy die-casting housing for heavy-duty outdoor lighting applications.
- ✧ Casting-integral heat sink with fins increased air flow velocity providing maximum passive thermal management.
- ✧ Easy drainage fins system.
- ✧ Separate LED light engine and driver box for easy maintenance.
- ✧ Tool-less design for replace the LED driver without any tool.
- ✧ Large driver box complies with Meanwell HVG series drivers.
- ✧ Both cover and bottom of the driver box have the GND bosses for security.
- ✧ Plastic electrostatic spraying to resist corrosion, chipping and fading.

MOONLIGHT TECHNOLOGY LIMITED

- ✧ Adjustable knuckle slip fitter with SUS304 stainless steel hardware secures fixture to pole arm.
- ✧ 5mm high light transmittance tempered glass diffuser.
- ✧ Silicon gaskets.
- ✧ SUS304 stainless steel bolts and clips for fastening.
- ✧ Standard S6000 socket and twist lock photocell mounting platform for lighting control.
- ✧ IP66 rated, protect from all dust and harsh weather.
- ✧ Standard Gray finish.
- ✧ Easy to assemble, install and linemen friendly maintain.

Mechanical Dimensions

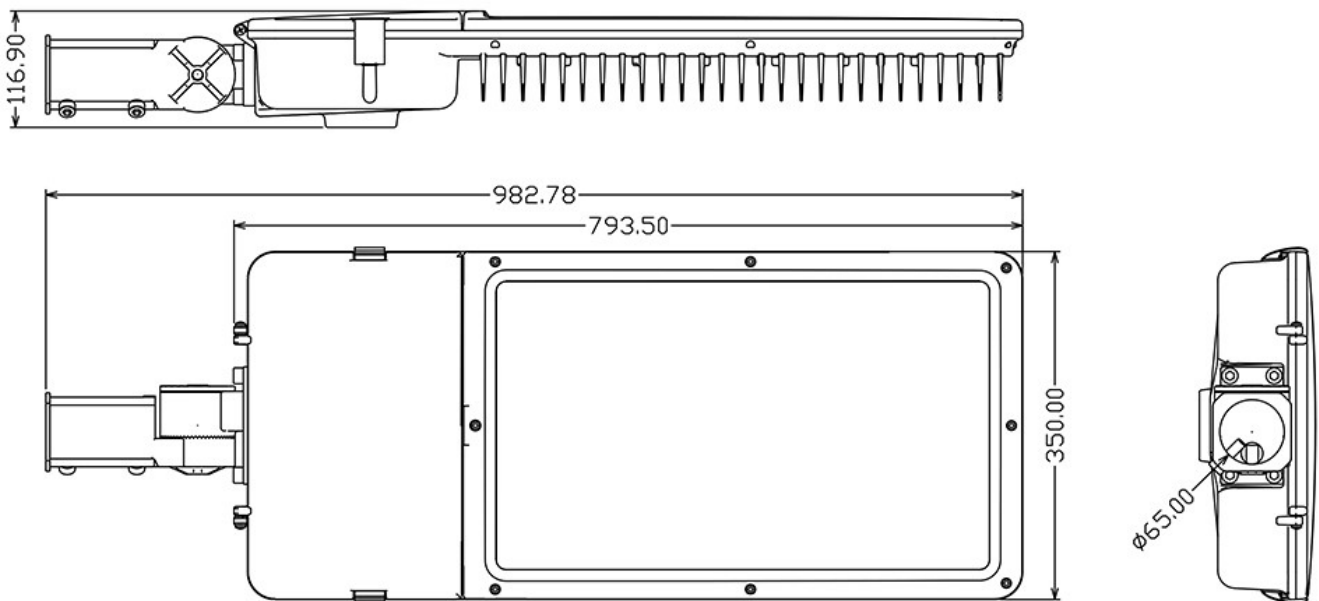

MOONLIGHT TECHNOLOGY LIMITED

Parameter

Model No.	LED Street Light Housing MLT-SLH-BL-II
Dimension of Housing	98.3cm(L)*35cm(W)*11.7cm(H)
Fixture Material	Die-casting Aluminum Alloy
Surface Finish Color	Gray or Customized color
Material of Diffuser	High Transmittance Tempered glass
Effective MCPCB Mounting Size	506.5mm(L)* 300mm(W)
Recommended LED Power	180W to 320W
Driver Box Dimension	315mm(L)* 175mm(W)* 93mm(H)
Pole Mounting	Accommodates up to Φ 65mm pipe
Adjustable Slip Fitter	-90° to +90°
Standard Photocell	Optional
IP Rating	IP66

Pictures

Front View

Back View



MOONLIGHT TECHNOLOGY LIMITED

Packing Information

Net Weight	12.72kg/PCS
Gross weight	14kg/carton
Quantity	1PCS/ carton
Carton Size	100cm(L)* 38.5cm(W)* 18cm(H)

Application

This heavy-duty, modern design and cost-effective LED street light housing fixture is typically used as 180W-240W LED street lighting fixture. LED street lighting is used extensively in urban settings, along small town downtown main streets, in residential neighborhoods, in commercial districts, public squares, in industrial parks, at interstate highway interchanges, bridges, and rural intersections.